

January 2024
FL974 A-F

Emissions Recall: Cummins DEF Sensor Shortage

Models Affected: Specific model years 2016-2022 Freightliner Cascadia, Business Class M2, 108SD, 114SD, 122SD; Western Star 4700, 4900, 49X; TBB EFX, HDX, MVP-EF, Saf-T-Liner C2 vehicles; and FCCC MB, S2C, XB, MT45, MT55, S2RV, XC chassis, manufactured January 7, 2016, through September 28, 2021, equipped with Cummins engines.

General Information

Due to a market shortage, diesel exhaust fluid (DEF) sensors were unavailable. Pursuant to an agreement with the U.S. Environmental Protection Agency, California Air Resources Board, and certifying emission regulators in Canada, certain vehicles with Cummins engines were equipped with engine software that was temporarily modified to account for continued operation without the required DEF sensors. The conditions of that agreement required recalling those engines to install DEF sensors and corresponding software once the sensors became available. To ensure customers' full protection under the emission warranty on these engines/equipment by federal law, and customers' rights to participate in future recalls, it is recommended that these engines/equipment be serviced as soon as possible. Failure to do so could be considered improper maintenance.

A new DEF header will be installed, and the engine software will be updated. Repairs will be performed by Daimler Truck North America authorized service facilities.

There are approximately 5,946 vehicles involved in this campaign.

Additional Repairs

Dealers must complete all outstanding Recall and Field Service campaigns prior to the sale or delivery of a vehicle. A Dealer will be liable for any progressive damage that results from its failure to complete campaigns before sale or delivery of a vehicle.

Work Instructions

Please refer to the attached work instructions. Prior to performing the campaign, check the vehicle for a completion sticker (Form WAR260).

Replacement Parts

Replacement parts are now available and can be obtained by ordering the part number(s) listed below from your facing Parts Distribution Center (PDC).

If our records show your dealership has ordered any vehicles involved in campaign number FL974, a list of the customers and vehicle identification numbers will be available on the DTNA Portal via OWL. Please refer to this list when ordering parts for this recall.

Table 1 - Replacement Parts for FL974

Campaign Number	Part Number	Part Description	Qty.
FL974 A	04-31354-004	HEADER-SSI,CONC,6 BOLT,CMNS	1 ea
FL974 B-C	04-36003-000	HEADER-DEF,10G,SSI	1 ea
FL974 D	04-36002-000	HEADER-DEF,11.5G,SSI	1 ea
FL974 E	04-36004-000	HEADER-DEF,15G,SSI	1 ea
FL974 F	04-31353-005	HEADER-SSI,CONC,SAE FLG,CMNS	1 ea
ALL GROUPS	WAR260	Completion Sticker	1 ea

Table 1

January 2024
FL974 A-F

Removed Parts

U.S. and Canadian Dealers, please follow Warranty Failed Parts Tracking shipping instructions for the disposition of all removed parts. Export distributors, please destroy removed parts unless otherwise advised.

Labor Allowance

Table 2 - Labor Allowance

Campaign Number	Procedure	Time Allowed (hours)	SRT Code	Corrective Action
FL974 A	Install DEF Header 6-Gal, Update Software	1.8	996-R211A	12-Repair Recall/Campaign
FL974 B	Install DEF Header 10-Gal, Update Software	2.1	996-R211B	12-Repair Recall/Campaign
FL974 C-E	Install DEF Header 10/11.5/15 Gal, Update Software	2.0	996-R211C	12-Repair Recall/Campaign
FL974 F	Install DEF Header 13/23 Gal, Update Software	2.4	996-R211D	12-Repair Recall/Campaign

Table 2

IMPORTANT: When the recall has been completed, locate the base completion label in the appropriate location on the vehicle, and attach the red completion sticker provided in the recall kit (Form WAR260). If the vehicle does not have a base completion label, clean a spot on the appropriate location of the vehicle and first attach the base completion label (Form WAR259). If a recall kit is not required or there is no completion sticker in the kit, write the recall number on a blank sticker and attach it to the base completion label.

Claims for Credit

You will be reimbursed for your parts, labor, and handling (landed cost for Export Distributors) by submitting your claim through the Warranty system within 30 days of completing this campaign. Please reference the following information in OWL:

- Claim type is **Recall Campaign**.
- In the FTL Authorization field, enter the campaign number and appropriate condition code (e.g. **FL974-A, FL974-B, etc.**).
- In the Primary Failed Part Number field, enter **25-FL974-000**.
- In the Parts field, enter the appropriate part number(s) as shown in the Replacement Parts Table.
- In the Labor field, first enter the appropriate SRT from the Labor Allowance Table. For administrative time, enter SRT 939-6010A for 0.3 hours (0.4 hours for RVs).
- For OWL, the VMRS Component Code is **F99-999-005** and the Cause Code is **A1 - Campaign**.
- **U.S. and Canada -- Reimbursement for Prior Repairs.** When a customer asks about reimbursement, please do the following:
 - Accept the documentation of the previous repair.
 - Make a brief check of the customer's paperwork to see if the repair may be eligible for reimbursement. (See the "Copy of Owner Letter" section of this bulletin for reimbursement guidelines for this recall.)
 - Submit a Campaign Pre-Approval inquiry to the Warranty Campaigns Department for a decision and authorization number.
 - Include the approved amount on your claim in Other Charges section.

January 2024
FL974 A-F

- In the claim story, first note the authorization number and that the claim includes a reimbursement.
- Retain the documentation and provide it to Warranty Campaigns or Claims Processing if requested.
- When your claim is paid, reimburse the customer the appropriate amount.

IMPORTANT: OWL must be viewed prior to performing the recall to ensure the vehicle is involved and the campaign has not been previously completed. Also, check for a completion sticker prior to beginning work.

U.S. and Canadian dealers, contact the Warranty Campaigns Department via the Warranty Support Center (WSC), located on the DTNA Portal., if you have any questions. Export distributors, submit a WSC ticket or contact your International Service Manager.

U.S. and Canadian Dealers: To return excess kit inventory related to this campaign, U.S. dealers must submit a Parts Authorization Return (PAR) to the Memphis PDC. Canadian dealers must submit a PAR to their facing PDC. All kits must be in resalable condition. PAR requests must include the original purchase invoice number. Export Distributors: Excess inventory is not returnable.

The letter notifying U.S. and Canadian vehicle owners is included for your reference.

Please note that the National Traffic and Motor Vehicle Safety Act, as amended (Title 49, United States Code, Chapter 301), requires the owner's vehicle(s) be corrected within a reasonable time after parts are available to you. The Act states that failure to repair a vehicle within 60 days after tender for repair shall be prima facie evidence of an unreasonable time. However, circumstances of a particular situation may reduce the 60 day period. Failure to repair a vehicle within a reasonable time can result in either the obligation to (a) replace the vehicle with an identical or reasonably equivalent vehicle, without charge, or (b) refund the purchase price in full, less a reasonable allowance for depreciation. The Act further prohibits dealers from selling a vehicle unless all outstanding recalls are performed. Any lessor is required to send a copy of the recall notification to the lessee within 10 days. Any subsequent stage manufacturer is required to forward this notice to its distributors and retail outlets within five working days.

January 2024
FL974 A-F

Copy of Notice to Owners

Emissions Recall: Cummins DEF Sensor Shortage

US: Your vehicle may be equipped with an exhaust system that violates Federal and/or California standards and regulations. **CAN:** This notice is sent to you in accordance with the requirements of the Canadian Environmental Protection Act, 1999.

Due to a market shortage, diesel exhaust fluid (DEF) sensors were unavailable. Pursuant to an agreement with the U.S. Environmental Protection Agency, California Air Resources Board, and certifying emission regulators in Canada, certain vehicles with Cummins engines were equipped with engine software that was temporarily modified to account for continued operation without the required DEF sensors. The conditions of that agreement required recalling those engines to install DEF sensors and corresponding software once the sensors became available. To ensure customers' full protection under the emission warranty on these engines/equipment by federal law, and customers' rights to participate in future recalls, it is recommended that these engines/equipment be serviced as soon as possible. Failure to do so could be considered improper maintenance.

Daimler Truck North America LLC (DTNA), on behalf of its Freightliner Trucks division, and wholly owned subsidiaries Western Star Truck Sales, Freightliner Custom Chassis Corporation (FCCC), and Thomas Built Buses (TBB), is initiating emissions recall FL974 A-F to modify specific model years 2016-2022 Freightliner Cascadia, Business Class M2, 108SD, 114SD, 122SD; Western Star 4700, 4900, 49X; TBB EFX, HDX, MVP-EF, Saf-T-Liner C2 vehicles; and FCCC MB, S2C, XB, MT45, MT55, S2RV, XC chassis', manufactured January 7, 2016, through September 28, 2021, equipped with Cummins engines.

A new DEF header will be installed, and the engine software will be updated. Repairs will be performed by Daimler Truck North America authorized service facilities.

Vehicle performance, other engine components, or drivability are not affected. The DEF sensor is used to indicate how much DEF is left in the tank. Failure to show an accurate level of DEF may lead to emission concerns.

Please contact an authorized DTNA dealer to arrange to have the recall performed and to ensure that parts are available at the dealership. To locate a dealer, search online at <https://northamerica.daimlertruck.com/contact-us>. Scroll down to 'Locate a Dealer', and search for a Freightliner location. The recall will take approximately two to two and a half hours and will be performed **free of charge**. You may also confirm your vehicle's involvement in this recall at URL: <https://dtna-dlrinfo.prd.freightliner.com:48518/VinLookup/vin-module/getVinLookupPage>.

If you reside in the State of California, the repairing facility will provide a certificate showing that your vehicle has had the recall completed. This certificate may be required as a condition of vehicle registration or operation.

If you do not own the vehicle that corresponds to the identification number(s), which appears on the recall notification, please return the notification to the Warranty Campaigns Department with any information you can furnish that will assist us in locating the present owner. If you have leased this vehicle, federal law requires that you forward this notice to the lessee within 10 days. If you are a subsequent stage manufacturer, federal law requires that you forward this notice to your distributors and retail outlets within five working days. If you have paid to have this recall condition corrected prior to this notice, you may be eligible to receive reimbursement. Please see the reverse side of this notice for details.

If you have questions about this recall, please contact the Warranty Campaigns Department at (800) 547-0712, 7:00 a.m. to 4:00 p.m. Pacific Time, Monday through Friday, e-mail address dtna.warranty.campaigns@daimlertruck.com. For other concerns, you may contact the Customer Assistance Center at (800) 385-4357.

We regret any inconvenience this action may cause, but feel certain you understand our interest in being compliant with motor vehicle emissions regulations.

WARRANTY CAMPAIGNS DEPARTMENT

Enclosure

January 2024
FL974 A-F

Reimbursement to Customers for Repairs Performed Prior to Recall

If you have already **paid** to have this recall condition corrected you may be eligible to receive reimbursement.

Requests for reimbursement may include parts and labor. Reimbursement may be limited to the amount the repair would have cost if completed by an authorized Daimler Truck North America LLC dealer. The following documentation must be presented to your dealer for consideration for reimbursement.

Please provide original or clear copies of all receipts, invoices, and repair orders that show:

- The name and address of the person who paid for the repair
- The Vehicle Identification Number (VIN) of the vehicle that was repaired
- What problem occurred, what repair was done, when the repair was done
- Who repaired the vehicle
- The total cost of the repair expense that is being claimed
- Proof of payment for the repair (such as the front and back of a cancelled check or a credit card receipt)

Reimbursement will be made by check from your Daimler Truck North America LLC dealer.

Please speak with your Daimler Truck North America LLC authorized dealer concerning this matter.

January 2024
FL974 A-F

Work Instructions

Subject: Cummins DEF Sensor Shortage

Models Affected: Specific model years 2016-2022 Freightliner Cascadia, Business Class M2, 108SD, 114SD, 122SD; Western Star 4700, 4900, 49X; TBB EFX, HDX, MVP-EF, Saf-T-Liner C2 vehicles; and FCCC MB, S2C, XB, MT45, MT55, S2RV, XC chassis, manufactured January 7, 2016, through September 28, 2021, equipped with Cummins engines.

FL974 A: FTL & WST 6-Gallon Tank Header

1. Check the base label (Form WAR259) for a completion sticker for FL974 (Form WAR260) indicating this work has been done. The base label is usually located on the passenger-side door, about 12 inches (30 cm) below the door latch. If a recall completion sticker is present, no work is needed. If there is no sticker, proceed with the next step.
2. Park the vehicle on a level surface, shut down the engine, and set the parking brake. Chock the tires.
3. Open the hood.

 **WARNING**

Do not remove or loosen the radiator cap until the engine and cooling system have completely cooled. Use extreme care when removing the cap. A sudden release of pressure from removing the cap prior to the system cooling can result in a surge of scalding coolant that could cause serious personal injury.

4. To prevent leakage from the DEF tank connections, recover the engine coolant, and store it in a clean container.
5. If so equipped, remove the DEF tank beauty cover.
6. Transfer enough DEF from the tank to be able to lift the DEF tank off the mounting bracket. Store the removed DEF in a clean container.

IMPORTANT: Wait at least five minutes after shutting down the engine to service the DEF lines. The system requires time to purge the DEF from the lines.

NOTICE

To separate the DEF fittings, push the line coupling in towards the male connector to move the holding clip to the unlocked position, then compress the prongs of the holding clip and pull the line off of the male connector. Failure to properly remove a DEF line can result in damage to a line coupling or DEF port.

January 2024
FL974 A-F

7. Remove the DEF lines from the supply and return ports. See [Fig. 1](#).
8. Remove the wiring harness connections from the tank header unit. See [Fig. 1](#).
9. Remove the coolant lines from the supply and return ports. See [Fig. 1](#).
10. If another chassis-mounted component is located directly on the rear of the DEF tank, check if the component is mounted close enough to prevent the tank from sliding off the mounting studs. If so equipped, remove the fasteners that secure the tank assembly to the frame casting, and remove the assembly from the frame casting. Remove the two capscrews that secure the tank and retaining washers on the mounting studs. See [Fig. 1](#).
11. Slide the tank off of the mounting studs.

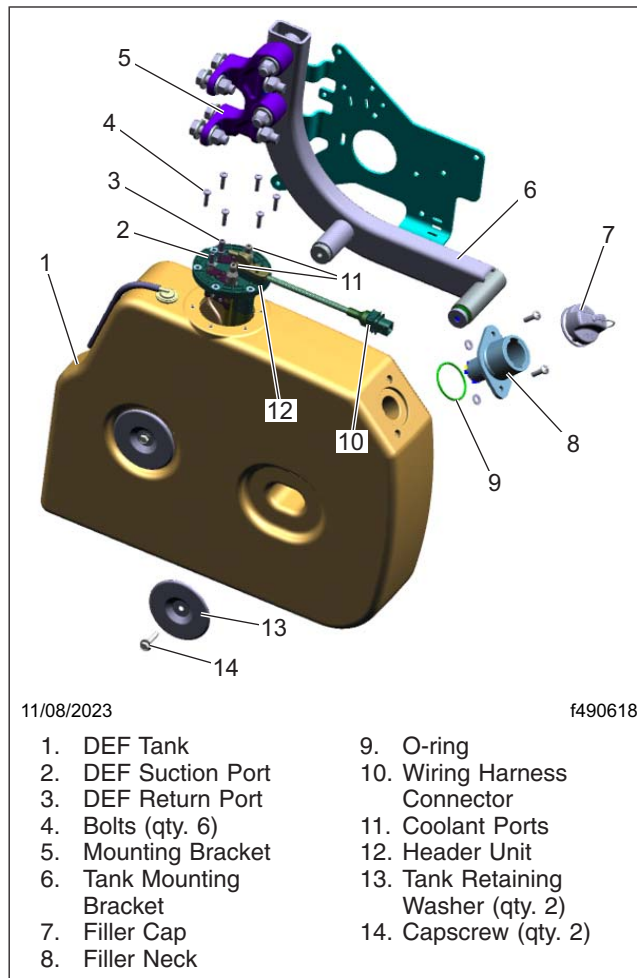

Fig. 1, 6-Gallon DEF Tank Mounting Assembly

NOTICE

The foot of the header is oriented away from the filler port. It must be ‘maneuvered’ out of the tank. Applying excessive force to the header during removal or installation may damage it.

12. Remove the existing header unit from the tank.
 - 12.1 Raise the header unit up until it stops (about eight inches).

January 2024
FL974 A-F

- 12.2 Rock the unit away from the filler neck to clear the internal structure. Then, lift unit out of the tank.
 13. Install a new header unit into the tank.
 - 13.1 Position the foot of the unit pointing away from the filler neck, and slide it into the tank.
 - 13.2 Lower the unit until it contacts the inner structure, then carefully rock the top towards the filler neck working the unit into the tank.
 - 13.3 Lower the unit into position.
 - 13.4 Install the fasteners and tighten 72 lbf·in (813 N·cm).
 14. Slide the tank onto the mounting studs.
 15. Install the two tank retaining washers on the tank mounting studs.
 16. Install the two capscrews onto the mounting studs, securing the tank and retaining washers on the tank mounting studs. Tighten the capscrews 11 to 18 lbf·ft (15 to 24 N·m).
 17. If the tank bracket was removed from the frame casting, install the tank assembly on the frame casting. Tighten the four tank assembly mounting bolts 112 lbf·ft (152 N·m).
 18. Install the coolant supply and return lines to the coolant ports on the tank.

IMPORTANT: To connect the DEF lines, push the line coupling on the male connector of the DEF port. Then, gently pull back the coupling to engage the holding clip in the locked position.
 19. Clean any DEF crystals from the DEF header ports on the tank and the line fittings.
 20. Install the DEF supply and return lines to the DEF ports on the back of the tank.
 21. Install the wiring harness connections to the tank header unit.
 22. Fill the DEF tank with the fluid recovered during the removal process.
 23. Fill the cooling system and check for leaks. Perform any bleeding procedures required by the engine supplier. See *Group 20* of the applicable *Workshop Manual*.
- NOTE: Following the Cummins standard practice, to prevent loss of fault codes on the electronic control module (ECM), ensure that all job images and other troubleshooting procedures are documented before downloading the ECM calibration.
24. Update the ECM calibration code.
 - 24.1 For Cummins engine, connect the Cummins INSITE™ service tool to the vehicle's electronic data link.
 - 24.2 Find and note the current calibration code.

NOTE: If you have updated the ECM to the same code on a previous vehicle, Cummins INSITE™ may have the new calibration stored.
 - 24.3 Log in to [Cummins QuickServe®](#), and go to the 'DEF Header ECM' look-up tool. Use the current code to search for the new calibration code. For detailed instructions, see **Cummins technical service bulletin 210187**.
 - 24.4 Install the new calibration code.
 25. Switch OFF the key and disconnect the service tool.
 26. Clean a spot on the base label (Form WAR259) and attach a recall completion sticker for FL974 (Form WAR260), indicating this work has been completed.

January 2024
FL974 A-F

FL974 B: TBB 10-Gallon Tank Header

1. Park the vehicle on a level surface, shut down the engine, and set the parking brake. Chock the tires.

NOTE: The main power disconnect switch (MPDS) is located inside the battery box compartment.

2. Turn the MPDS to the OFF position.
3. Disconnect the negative battery cables on the batteries.

WARNING

Do not remove or loosen the radiator cap until the engine and cooling system have completely cooled. Use extreme care when removing the cap. A sudden release of pressure from removing the cap prior to the system cooling can result in a surge of scalding coolant that could cause serious personal injury.

4. Remove the radiator cap.
5. Transfer enough DEF from the tank to be able to lift the DEF tank off the mounting bracket. Store the removed DEF in a clean container.
6. Place the floor jack under the DEF tank lower support and remove the fasteners that attaches the lower support to the tank mounting bracket. See [Fig. 2](#).

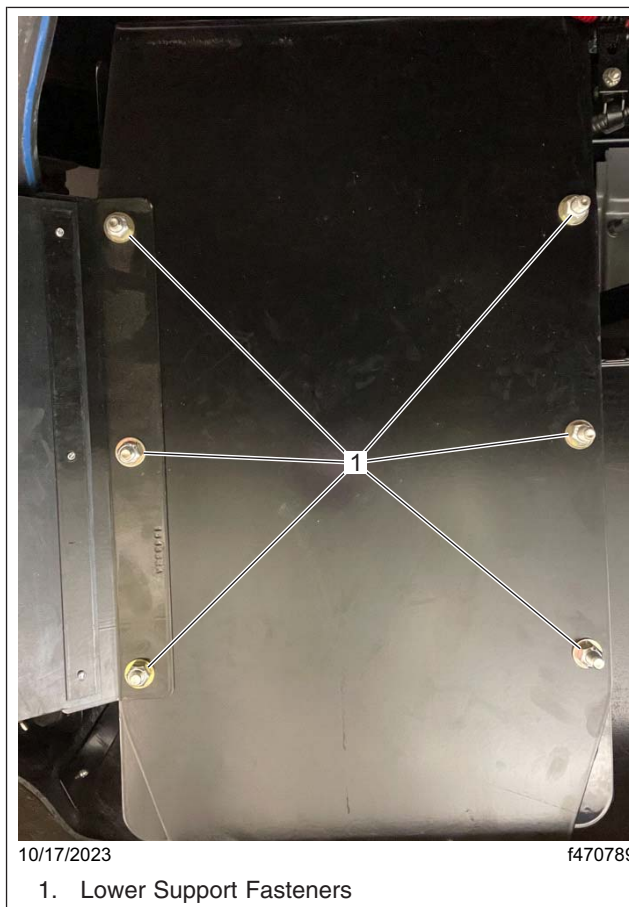

Fig. 2, DEF Tank Lower Support

January 2024
FL974 A-F

7. Slightly lower the DEF tank and ensure that the harnesses and lines are not stretched.

IMPORTANT: Do not lower the tank more than five-inch to prevent the wiring and the hose damage.

8. Working through the DEF tank-side door, place clamps on the DEF tank coolant lines, to prevent any leakage. Store any residual coolant in a clean container. See [Fig. 3](#).

IMPORTANT: Wait at least five minutes after shutting down the engine to service the DEF lines. The system requires time to purge the DEF from the lines.

9. Remove the coolant lines from the supply and return ports as shown in [Fig. 3](#).

10. Place a clean drain pan underneath the tank to collect the draining DEF. Uncontaminated DEF may be reused.

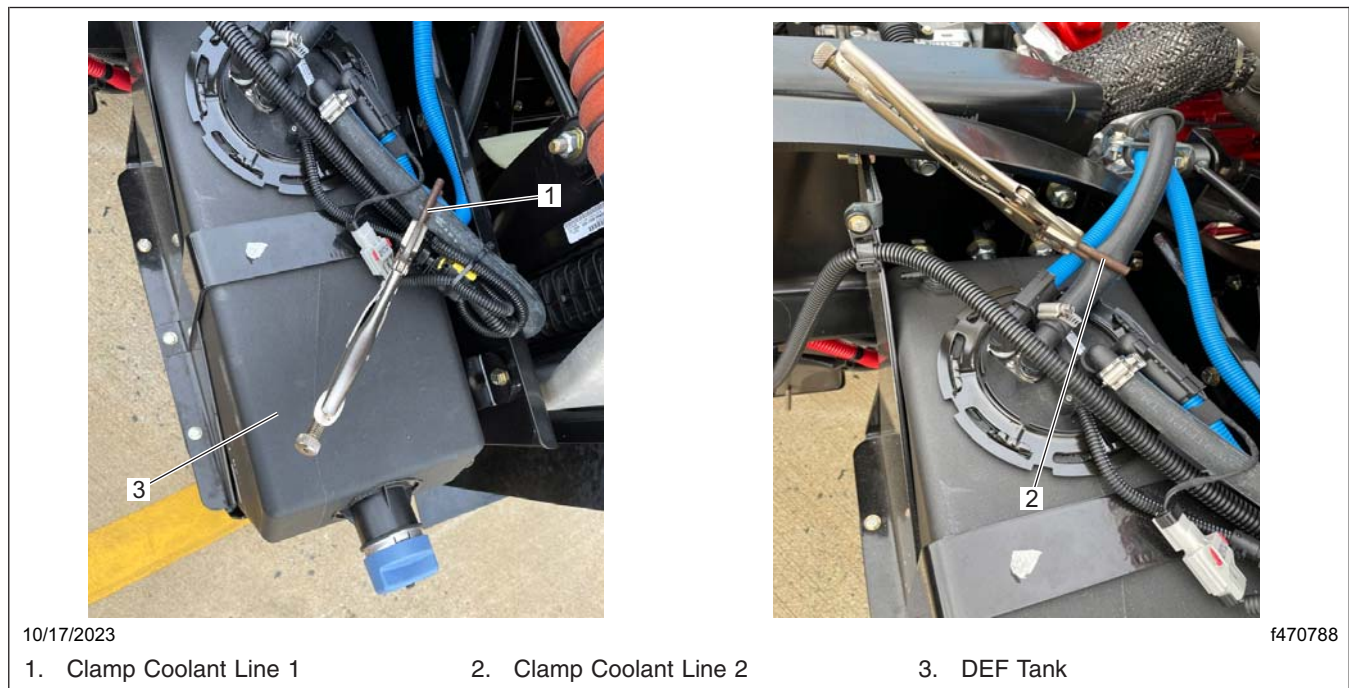

Fig. 3, Location of the DEF Tank Coolant Lines

January 2024
FL974 A-F

11. Remove the DEF line heater wiring harnesses from the DEF lines at the tank. See [Fig. 4](#).

NOTICE

To separate the DEF fittings, push the line coupling in towards the male connector to move the holding clip to the unlocked position, then compress the prongs of the holding clip and pull the line off of the male connector. Failure to properly remove a DEF line can result in damage to a line coupling or DEF port.

NOTICE

Discard contaminated DEF and coolant in accordance with EPA regulations.

12. Remove the DEF lines from the supply and return ports. See [Fig. 4](#).

13. Remove the wiring harness connector from the DEF tank header unit. See [Fig. 4](#).

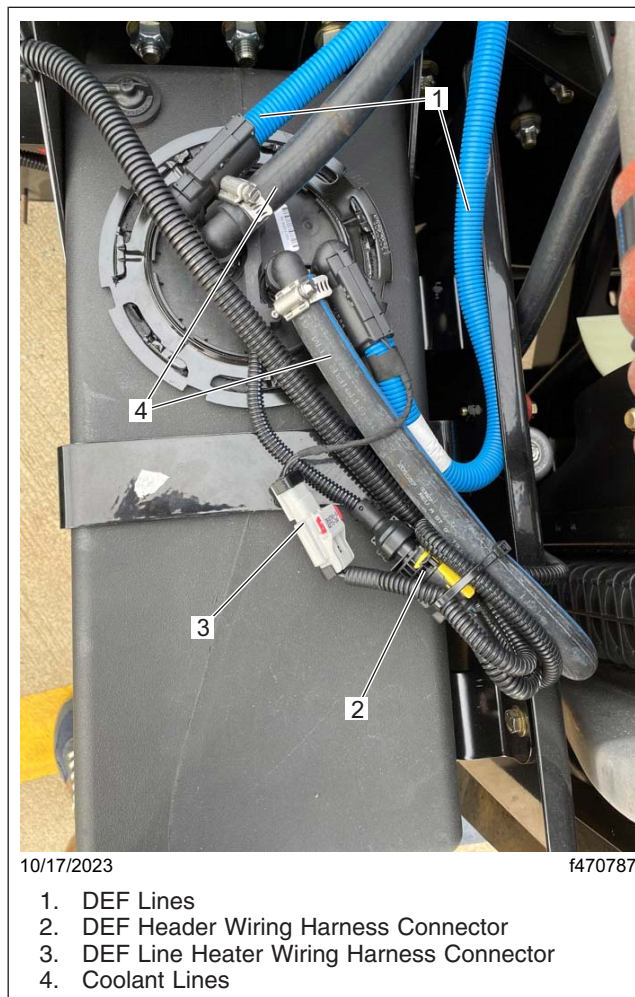

Fig. 4, Removal of DEF Tank Connections

January 2024
FL974 A-F

14. Lower the DEF tank enough to gain access to the DEF header unit.

NOTE: Tool W001582000700 or similar may be used to remove header lockring.

15. Rotate the header lockring counter-clockwise to loosen it, then remove the lockring. See [Fig. 5](#).

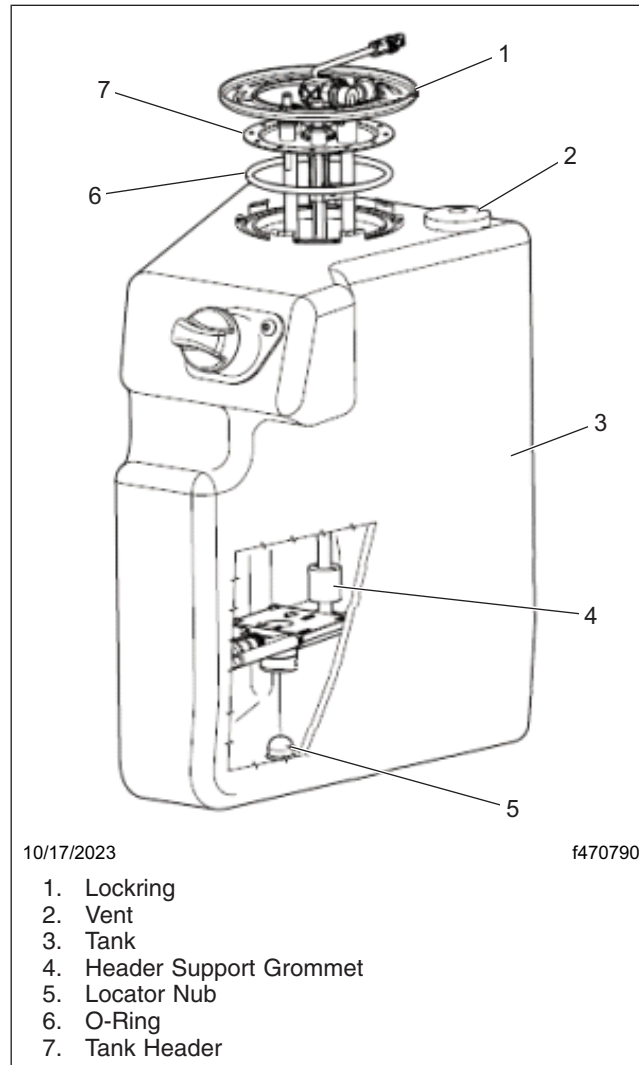

Fig. 5, 10-Gallon DEF Tank Mounting Assembly

16. Remove the header unit from the tank by pulling the assembly straight up. Then, tilt it to pull the horizontal end clear of the tank.

17. Install the new header unit (04-36003-000) by tilting it to insert the horizontal end into the tank. Once the horizontal segment is inside the tank, tilt the header unit back to vertical position to settle the header support grommet on the locator nub.

18. Install the header lockring and rotate it clockwise to secure it to the tank. Make sure the O-ring, between the lockring and the tank, is in the molded groove and is not pinched when the lockring is rotated in place. See [Fig. 5](#).

19. Remove any white DEF crystals from the DEF ports on the header unit and the DEF line couplings.

January 2024
FL974 A-F

20. Position the DEF tank on the mounting bracket assembly. Then, lift it to the bracket enough to reconnect the wiring harnesses, coolant, and DEF lines.

NOTE: To connect a DEF line, push the line coupling on the male connector on the DEF port. Then, gently pull back the coupling to engage the holding clip in the locked position.

21. Connect the coolant valve, DEF level and temperature sensor wiring harnesses to the tank header unit.

22. Install the DEF supply and return lines to the DEF ports on the tank header unit.

23. Install the DEF line heater wiring harnesses to the DEF lines at the tank.

24. Install the coolant lines to the tank header unit.

25. Remove the clamps from the coolant lines of the DEF Tank.

26. Lift the DEF tank with the mounting bracket and install the lower support fasteners that were removed.

27. Fill the DEF Tank.

28. Fill the cooling system and check for leaks. Perform any bleeding procedures required by the engine supplier. See *Group 20* of the applicable *Workshop Manual*.

NOTE: Following the Cummins standard practice, to prevent loss of fault codes on the electronic control module (ECM), ensure that all job images and other troubleshooting procedures are documented before downloading the ECM calibration.

29. Update the ECM calibration code.

29.1 For Cummins engine, connect the Cummins INSITE™ service tool to the vehicle's electronic data link.

29.2 Find and note the current calibration code.

NOTE: If you have updated the ECM to the same code on a previous vehicle, Cummins INSITE™ may have the new calibration stored.

29.3 Log in to [Cummins QuickServe®](#), and go to the 'DEF Header ECM' look-up tool. Use the current code to search for the new calibration code. For detailed instructions, see **Cummins technical service bulletin 210187**.

29.4 Install the new calibration code.

30. Switch OFF the key and disconnect the service tool.

FL974 C–E: FCCC 10/11.5/15-Gallon Tank Header

1. Check the base label (Form WAR259) for a completion sticker for FL974 (Form WAR260) indicating this work has been done. The base label is usually located on the passenger-side door, about 12 inches (30 cm) below the door latch. If a recall completion sticker is present, no work is needed. If there is no sticker, proceed with the next step.

2. Park the vehicle on a level surface, shut down the engine, and set the parking brake. Chock the tires.

3. Open the hood.

WARNING

Do not remove or loosen the radiator cap until the engine and cooling system have completely cooled. Use extreme care when removing the cap. A sudden release of pressure from removing the cap prior to the system cooling can result in a surge of scalding coolant that could cause serious personal injury.

4. To prevent leakage from the DEF tank connections, recover the engine coolant, and store it in a clean container.

January 2024
FL974 A-F

5. Transfer enough DEF from the tank to be able to lift the DEF tank off the mounting bracket. Store the removed DEF in a clean container.

IMPORTANT: Wait at least five minutes after shutting down the engine to service the DEF lines. The system requires time to purge the DEF from the lines.

NOTICE

To separate the DEF fittings, push the coupling towards the male connector. After that, shift the holding clip to the unlocked position, and squeeze the prongs of the holding clip to remove it.

6. Remove the DEF lines from the supply and return ports.
7. Remove the wiring harness connections from the DEF tank header unit.
8. Remove the coolant lines from the supply and return ports.
9. Remove the fasteners that secure the tank retaining bracket to the tank mounting cage. See [Fig. 6](#).
10. Remove the tank from the mounting cage.

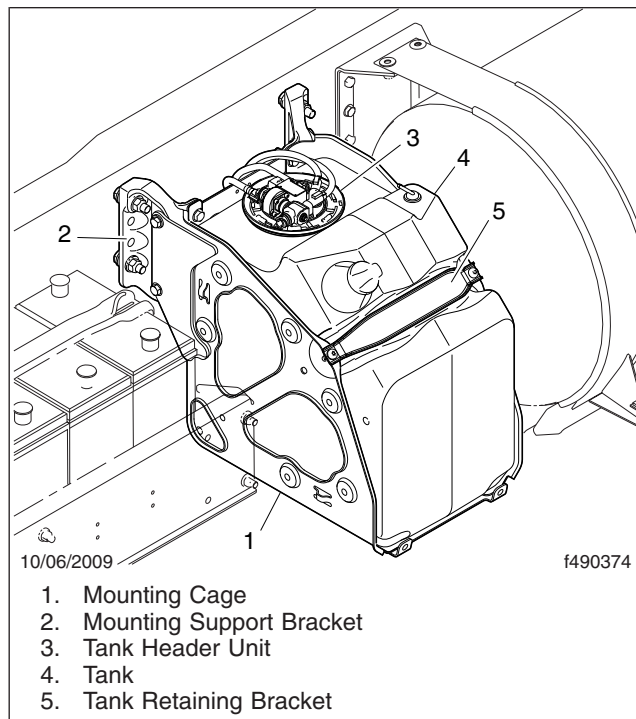

Fig. 6, 10-, 11.5-, or 15-Gallon DEF Tank Mounting Assembly

January 2024
FL974 A-F

NOTE: Tool W001582000700 or similar may be used to remove header lockring.

11. Rotate the header lockring counter-clockwise to loosen it, then remove the lockring. See [Fig. 7](#).
12. Remove the DEF header unit from the tank by pulling the assembly straight up. Then, tilt it to pull the horizontal end clear of the tank. See [Fig. 7](#).

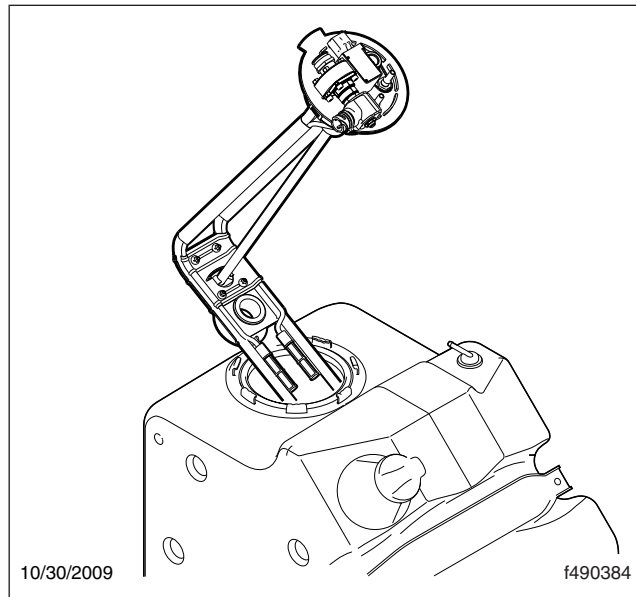

Fig. 7, Header Unit

13. Install the new header unit to the tank.
 - 13.1 Fit the header to the port in the tank.
 - 13.2 Adjust the header so the bottom section fits to the support feature in the bottom, and seat the header on the seal.
 - 13.3 Install the header lockring. Rotate it clockwise to secure it to the tank.
 14. Position the tank in the mounting cage.
 15. Install the retaining bracket on the tank cage and tighten the nuts 12 lbf-ft (16 N·m).
 16. Install the coolant supply and return line connections to the tank header unit.
- IMPORTANT:** To connect the DEF lines, push the line coupling on the male connector of the DEF port. Then, gently pull back the coupling to engage the holding clip in the locked position.
17. Clean any DEF crystals from the DEF header ports on the tank and the line fittings.
 18. Install the wiring harness connections to the tank header unit.
 19. Install the DEF supply and return lines to the DEF ports on the tank header unit.
 20. Fill the DEF tank with the fluid recovered during the removal process.
 21. Fill the cooling system and check for leaks. Perform any bleeding procedures required by the engine supplier. See *Group 20* of the applicable *Workshop Manual*.

NOTE: Following the Cummins standard practice, to prevent loss of fault codes on the electronic control module (ECM), ensure that all job images and other troubleshooting procedures are documented before downloading the ECM calibration.

January 2024
FL974 A-F

22. Update the ECM calibration code.
 - 22.1 For Cummins engine, connect the Cummins INSITE™ service tool to the vehicle's electronic data link.
 - 22.2 Find and note the current calibration code.

NOTE: If you have updated the ECM to the same code on a previous vehicle, Cummins INSITE™ may have the new calibration stored.
 - 22.3 Log in to **Cummins QuickServe®**, and go to the 'DEF Header ECM' look-up tool. Use the current code to search for the new calibration code. For detailed instructions, see **Cummins technical service bulletin 210187**.
 - 22.4 Install the new calibration code.
23. Switch OFF the key and disconnect the service tool.
24. Clean a spot on the base label (Form WAR259) and attach a recall completion sticker for FL974 (Form WAR260), indicating this work has been completed.

FL974 F: FTL & WST 13/23-Gallon Tank Header

1. Check the base label (Form WAR259) for a completion sticker for FL974 (Form WAR260) indicating this work has been done. The base label is usually located on the passenger-side door, about 12 inches (30 cm) below the door latch. If a recall completion sticker is present, no work is needed. If there is no sticker, proceed with the next step.
2. Park the vehicle on a level surface, shut down the engine, and set the parking brake. Chock the tires.
3. Open the hood.

 **WARNING**

Do not remove or loosen the radiator cap until the engine and cooling system have completely cooled. Use extreme care when removing the cap. A sudden release of pressure from removing the cap prior to the system cooling can result in a surge of scalding coolant that could cause serious personal injury.

4. To prevent leakage from the DEF tank connections, recover the engine coolant, and store it in a clean container.
5. If so equipped, remove the beauty cover, or the side fairing mounted on the frame.
6. Transfer enough DEF from the tank to be able to lift the DEF tank off the mounting bracket. Store the removed DEF in a clean container.

IMPORTANT: Wait at least five minutes after shutting down the engine to service the DEF lines. The system requires time to purge the DEF from the lines.

NOTICE

To separate the DEF fittings, push the line coupling in towards the male connector to move the holding clip to the unlocked position, then compress the prongs of the holding clip and pull the line off of the male connector. Failure to properly remove a DEF line can result in damage to a line coupling or DEF fitting.

7. Remove the DEF lines from the supply and return ports.
8. Remove the DEF line heater wiring harnesses from the DEF lines at the tank.
9. Remove the coolant lines from the supply and return ports.
10. If applicable, remove the vent lines and remote fill hoses from the tank.
11. Remove the vent and fill ports.

January 2024
FL974 A-F

12. Remove the fasteners that secure the tank retaining bracket to the tank mounting cage. See [Fig. 8](#).

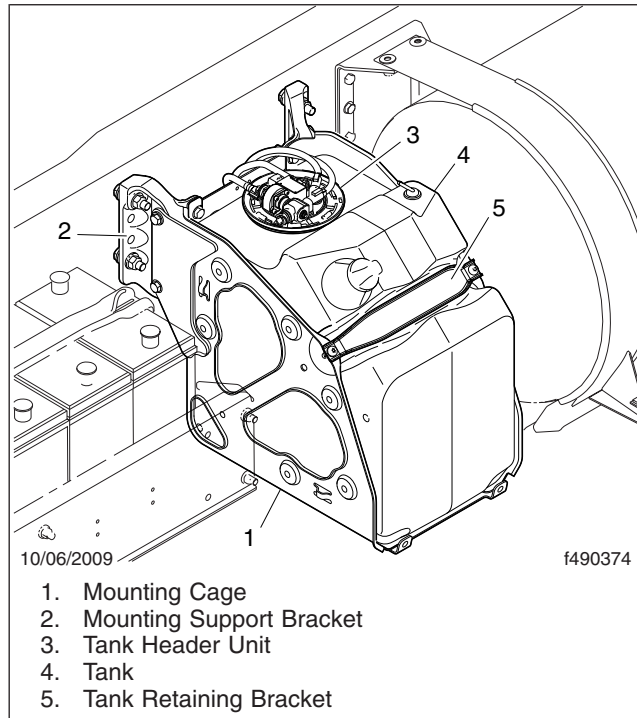

Fig. 8, 13- or 23-Gallon DEF Tank Mounting Assembly

13. Remove the tank from the mounting cage.

NOTE: Tool W001582000700 or similar may be used to remove header lockring.

14. Rotate the header lockring counter-clockwise to loosen it, then remove the lockring. See [Fig. 9](#).

15. Remove the DEF header unit from the tank by pulling the assembly straight up. Then, tilt it to pull the horizontal end out of the tank. See [Fig. 9](#).

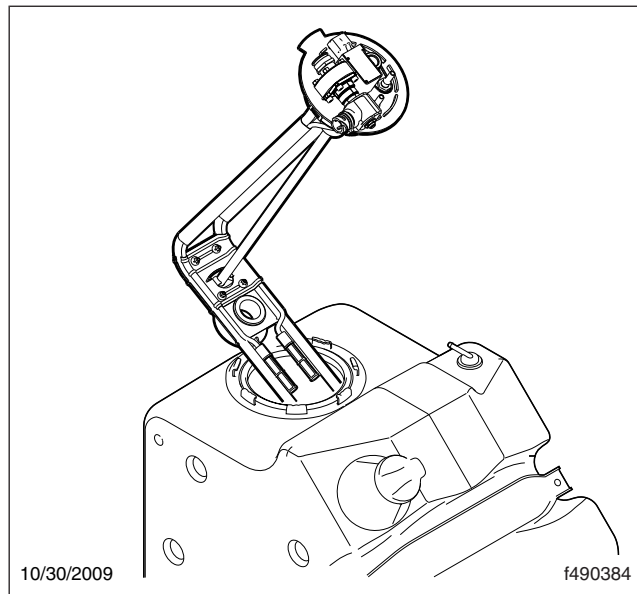

Fig. 9, Header Unit

January 2024
FL974 A-F

16. Install a new header unit to the tank.
 - 16.1 Fit the header to the port in the tank.
 - 16.2 Adjust the header so the bottom section fits to the support feature in the bottom, and seat the header on the seal.
 - 16.3 Install the header lockring. Rotate it clockwise to secure it to the tank.
17. Position the tank in the mounting cage.
18. Install the retaining bracket on the tank cage. Tighten the nuts 12 lbf-ft (16 N·m).
19. If applicable, lubricate the remote fill port seal and the vent line port with P80® Rubber lubricant emulsion.
20. Install the fill port and turn by hand until snug. Tighten the fill port 96 lbf-in (1085 N·cm).
21. Install the vent port and tighten 18 lbf-in (203 N·cm).
22. Install the coolant supply and return line connections to the tank header unit.

IMPORTANT: To install DEF lines, push the line coupling on the male connector of the DEF port. Then, gently pull back the coupling to engage the holding clip in the locked position.

23. Clean any DEF crystals from the DEF header ports on the tank and the line fittings.
24. Install the DEF supply and return lines to the DEF ports on the back of the tank.
25. Install the wiring harness connections to the tank header unit.
26. Fill the DEF tank with the fluid recovered during the removal process.
27. Install the beauty cover, or the frame mounted side fairing. For detailed service information, see the applicable vehicle *Workshop Manual*.
28. Fill the cooling system and check for leaks. Perform any bleeding procedures required by the engine supplier. See *Group 20* of the applicable *Workshop Manual*.

NOTE: Following the Cummins standard practice, to prevent loss of fault codes on the electronic control module (ECM), ensure that all job images and other troubleshooting procedures are documented before downloading the ECM calibration.

29. Update the ECM calibration code.
 - 29.1 For Cummins engine, connect the Cummins INSITE™ service tool to the vehicle's electronic data link.
 - 29.2 Find and note the current calibration code.

NOTE: If you have updated the ECM to the same code on a previous vehicle, Cummins INSITE™ may have the new calibration stored.
 - 29.3 Log in to **Cummins QuickServe®**, and go to the 'DEF Header ECM' look-up tool. Use the current code to search for the new calibration code. For detailed instructions, see **Cummins technical service bulletin 210187**.
 - 29.4 Install the new calibration code.

30. Switch OFF the key and disconnect the service tool.
31. Clean a spot on the base label (Form WAR259) and attach a recall completion sticker for FL974 (Form WAR260), indicating this work has been completed.