

# Recall Campaign

Daimler Trucks  
North America LLC

August 2019  
FL818AB  
NHTSA #19V-444  
Transport Canada #2019-288

## Subject: TBB Bendix Air Disc Brake Calipers

**Models Affected: Specific Model Year 2010 to 2019 Thomas Built Buses Saf-T-Liner HDX, EFX, and C2 (Freightliner Custom Chassis B2 school bus chassis) buses manufactured March 16, 2009, through June 29, 2018.**

### General Information

Daimler Trucks North America LLC (DTNA), on behalf of its wholly owned subsidiaries, Freightliner Custom Chassis Corporation and Thomas Built Buses, has decided that a defect that relates to motor vehicle safety exists on the vehicles mentioned above.

There are approximately 11,000 vehicles involved in this campaign.

On certain buses, the Bendix air disc brake caliper on the left (driver side) rear corner may experience an unintended reduction in the gap between the brake pad and rotor (running clearance), during operation which can lead to a dragging brake. In addition, if the gap between the brake pad and rotor is eliminated, it may lead to high temperatures at the wheel end. The high temperatures may lead to the presence of smoke, smoke odor, or a potential for fire, which could result in school bus emergency evacuation procedures in uncontrolled traffic situations.

The left rear caliper will be inspected and replaced, if needed, with a new caliper containing an updated clearance adjustment mechanism.

### Additional Repairs

Dealers must complete all outstanding recall and field service campaigns prior to the sale or delivery of a vehicle. A Dealer will be liable for any progressive damage that results from its failure to complete campaigns before sale or delivery of a vehicle.

Owners may be liable for any progressive damage that results from failure to complete campaigns within a reasonable time after receiving notification.

### Work Instructions

Please refer to the attached work instructions.

### Replacement Parts

Replacement parts are now available and can be obtained by ordering from your facing Parts Distribution Center.

**Table 1** – Replacement Parts for FL818

Campaign Number	Kit Number	Description	Qty.
FL818A (TBB Buses)	BW K191738	FL818 BENDIX AXIAL CALIPER REPLACEMENT KIT	1 ea
FL818B (FCCC Chassis)	BW K191740	FL818 BENDIX VERTICAL CALIPER REPLACEMENT KIT	1 ea

Table 1

# Recall Campaign

Daimler Trucks  
North America LLC

August 2019  
FL818AB  
NHTSA #19V-444  
Transport Canada #2019-288

## Removed Parts

Calipers removed for FL818 will be returned to Bendix. Please use the following instructions. (Shipment is at no charge to the dealership.)

### Shipments of one or two (1 or 2) calipers

- Package one or two (1 or 2) calipers in the packaging from the Bendix recall kits
- Include a copy of the recall claim for each caliper in a shipment
- Ship to Bendix via UPS using account number 2AT516

### Shipments of three (3) or more calipers

- Palletize three (3) or more calipers
- Include a copy of the recall claim for each caliper in the shipment
- Ship pallets of three (3) or more calipers to Bendix with the completed shipment information form downloaded from: [http://www.bendix.com/en/servicessupport/recallcenter/recallcenter\\_1.jsp](http://www.bendix.com/en/servicessupport/recallcenter/recallcenter_1.jsp); call Central Transport at (586) 467-1900 to coordinate pick up

### Ship to Address:

Bendix Warranty Center  
1155 E Franklin St.  
Huntington, IN. 46750  
ATTN: Recall Returns

## Labor Allowance

Table 2 – Labor Allowance

Campaign Number	Procedure	Time Allowed (Hours)	SRT Code	Corrective Action
FL818AB	Inspect left rear caliper date code	0.3	996-R073A	06 – Inspect
FL818AB	Inspect and replace left rear caliper	1.5	996-R073B	12 – Repair Recall/Campaign

Table 2

## Claims for Credit

You will be reimbursed for your parts, labor, and handling by submitting your claim through the Warranty system within 30 days of completing this campaign. Please reference the following information in OWL:

- Claim Type is **Recall Campaign**.
- In the Campaign field, enter the campaign number (**FL818-A or FL818-B**)
- In the Primary Failed Part field, enter **25-FL818-000**.
- In the Parts section, enter the appropriate part number(s) as shown in the Replacement Parts Table. Removed calipers will be returned to Bendix. See the shipping instructions under “Removed Parts” above.
- In the Labor section, enter the appropriate SRT from the Labor Allowance Table.
- The VMRS Component Code is **F99-999-005** and the Cause Code is **A1 - Campaign**.

# Recall Campaign

Daimler Trucks  
North America LLC

August 2019

FL818AB

NHTSA #19V-444

Transport Canada #2019-288

- **U.S. and Canada – Reimbursement for Prior Repairs.** When a customer asks about reimbursement, please do the following:
  - Accept the documentation of the previous repair.
  - Make a brief check of the customer's paperwork to see if the repair may be eligible for reimbursement.
  - Submit a Recall Pre-Approval request for a decision and authorized amount.
  - Submit a "based on" claim for the approved pre-approval.
  - Attach the documentation to the pre-approval request.
  - When your claim is paid, reimburse the customer the appropriate amount.

**IMPORTANT:** OWL must be viewed prior to performing the recall to ensure the vehicle is involved and the campaign has not been previously completed. Also, check for a completion sticker prior to beginning work.

If you have any questions or need additional information, contact the Warranty Campaigns Department via Web inquiry at [DTNACconnect.com/WSC](http://DTNACconnect.com/WSC).

To return excess kit inventory related to this campaign, U.S. dealers must submit a Parts Authorization Return (PAR) to the Memphis PDC. Canadian dealers must submit a PAR to their facing PDC. All kits must be in resalable condition. PAR requests must include the original purchase invoice number.

The letter notifying U.S. and Canadian vehicle owners is included for your reference.

Please note that the National Traffic and Motor Vehicle Safety Act, as amended (Title 49, United States Code, Chapter 301), requires the owner's vehicle(s) be corrected within a reasonable time after parts are available to you. The Act states that failure to repair a vehicle within 60 days after tender for repair shall be prima facie evidence of an unreasonable time. However, circumstances of a particular situation may reduce the 60 day period. Failure to repair a vehicle within a reasonable time can result in either the obligation to (a) replace the vehicle with an identical or reasonably equivalent vehicle, without charge, or (b) refund the purchase price in full, less a reasonable allowance for depreciation. The Act further prohibits dealers from selling a vehicle unless all outstanding recalls are performed. Any lessor is required to send a copy of the recall notification to the lessee within 10 days. Any subsequent stage manufacturer is required to forward this notice to its distributors and retail outlets within five working days.

# Recall Campaign

Daimler Trucks  
North America LLC

August 2019  
FL818AB  
NHTSA #19V-444  
Transport Canada #2019-288

## Copy of Notice to Owners

### Subject: TBB Bendix Air Disc Brake Calipers

**The U.S. notice is used for reference:** This notice is sent to you in accordance with the requirements of the *National Traffic and Motor Vehicle Safety Act*.

Daimler Trucks North America LLC, on behalf of its wholly owned subsidiary, Thomas Built Buses, Inc., has decided that a defect which relates to motor vehicle safety exists on specific Model Year 2010 to 2019 Thomas Built Buses Saf-T-Liner HDX, EFX, and C2 (Freightliner Custom Chassis B2 school bus chassis) buses manufactured March 16, 2009, through June 29, 2018.

On certain buses, the Bendix air disc brake caliper on the left (driver side) rear corner may experience an unintended reduction in the gap between the brake pad and rotor (running clearance), during operation which can lead to a dragging brake. In addition, if the gap between the brake pad and rotor is eliminated, it may lead to high temperatures at the wheel end. The high temperatures may lead to the presence of smoke, smoke odor, or a potential for fire, which could result in school bus emergency evacuation procedures in uncontrolled traffic situations.

The left rear caliper will be inspected and replaced, if needed, with a new caliper containing an updated clearance adjustment mechanism.

Repairs will begin August 31<sup>st</sup>. **Please contact an authorized dealer to make an appointment.** The repair should take approximately two hours and will be performed at no charge to you. You may also confirm your vehicle's involvement in this recall at this URL: <https://dtna-dlrinfo.prd.freightliner.com:48518/VinLookup/vin-module/getVinLookupPage>.

If you do not own the vehicle that corresponds to the identification number(s) which appears on the Recall Notification, please return the notification to the Warranty Campaigns Department with any information you can furnish that will assist us in locating the present owner. If you have leased this vehicle, Federal law requires that you forward this notice to the lessee within 10 days. If you are a subsequent stage manufacturer, Federal law requires that you forward this notice to your distributors and retail outlets within five working days. If you have paid to have this recall condition corrected prior to this notice, you may be eligible to receive reimbursement. Please see the reverse side of this notice for more information.

If you have any questions about this recall, please contact the Warranty Campaigns Department at (800) 547-0712, 7:00 a.m. to 4:00 p.m., Monday through Friday. If you are not able to have the defect remedied without charge and within a reasonable time, you may wish to submit a complaint to the Administrator, National Highway Traffic Safety Administration, 1200 New Jersey Avenue, SE, Washington, DC 20590; or call the Vehicle Safety Hotline at (888) 3274236 (TTY: (800) 424-9153); or to <http://www.safercar.gov>.

We regret any inconvenience this action may cause but feel certain you understand our interest in motor vehicle safety.

THOMAS BUILT BUSES WARRANTY DEPARTMENT  
Enclosure

# Recall Campaign

Daimler Trucks  
North America LLC

---

August 2019  
FL818AB  
NHTSA #19V-444  
Transport Canada #2019-288

## Reimbursement to Customers for Repairs Performed Prior to Recall

If you have already **paid** to have this recall condition corrected you may be eligible to receive reimbursement.

Requests for reimbursement may include parts and labor. Reimbursement may be limited to the amount the repair would have cost if completed by an authorized Daimler Trucks North America LLC dealer. The following documentation must be presented to your dealer for consideration for reimbursement.

Please provide original or clear copies of all receipts, invoices, and repair orders that show:

- The name and address of the person who paid for the repair.
- The Vehicle Identification Number (VIN) of the vehicle that was repaired.
- What problem occurred, what repair was done, when the repair was done.
- Who repaired the vehicle.
- The total cost of the repair expense that is being claimed.
- Proof of payment for the repair (such as the front and back of a cancelled check or a credit card receipt).

Reimbursement will be made by check from your Daimler Trucks North America LLC dealer.

Please speak with your Daimler Trucks North America LLC authorized dealer concerning this matter

# Recall Campaign

Daimler Trucks  
North America LLC

August 2019  
FL818AB  
NHTSA #19V-444  
Transport Canada #2019-288

## Work Instructions

### Subject: TBB Bendix Air Disc Brake Calipers

**Models Affected: Specific Model Year 2010 to 2019 Thomas Built Buses Saf-T-Liner HDX, EFX, and C2 (Freightliner Custom Chassis B2 school bus chassis) buses manufactured March 16, 2009, through June 29, 2018.**

### Date/Production Code Inspection – All Vehicles

1. For FCCC chassis, check the base label (Form WAR259) for a completion sticker for FL818 (Form WAR260) indicating this work has been done. The base label is usually located above the driver's window. If a sticker is present, no work is needed. If there is no sticker, proceed with the next step. For TBB buses, confirm in OWL that FL818 is still open.
2. Park the vehicle on a level surface, shut down the engine, and set the parking brake. Chock the tires.
3. Drain all reservoirs to 0 psi (0 kPa).
4. Clean the exterior of the Bendix air disc brake assembly.
5. Inspect for the presence of a green dot in either location shown in **Figure 1**.  
If no green dot is present, continue with the next step.  
If a green dot is present, no further work is needed. For FCCC chassis in FL818B, clean a spot on the base label (Form WAR259). Write the recall number, FL818, on a completion sticker (Form WAR260), and attach it to the base label to indicate this recall has been completed. For TBB buses in FL818A, the procedure is complete.
6. Inspect the identification label on the caliper. (Remove paint coating if necessary.) See **Figures 1, 2, and 3**.  
If the manufacturing date code is January 2, 2009, through November 27, 2018, replace the caliper. The majority of buses will require a caliper replacement.  
If the manufacturing date code is **not** in the specified date range no further work is needed. For FCCC chassis in FL818B, clean a spot on the base label (Form WAR259), write the recall number, FL818, on a red completion sticker, and attach it to the base label. For TBB buses in FL818A, the procedure is complete.
7. Start the engine to pressurize the air tanks. Once full air pressure is achieved, shut down the engine.

# Recall Campaign

August 2019  
FL818AB  
NHTSA #19V-444  
Transport Canada #2019-288

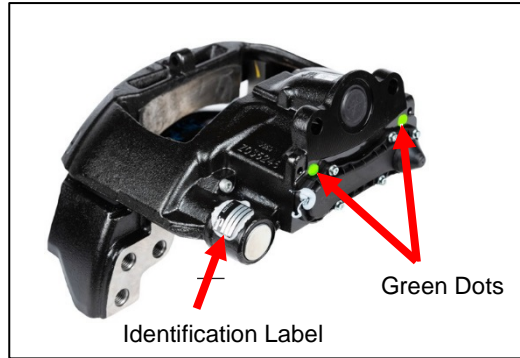

Figure 1: Locating Information on the Caliper

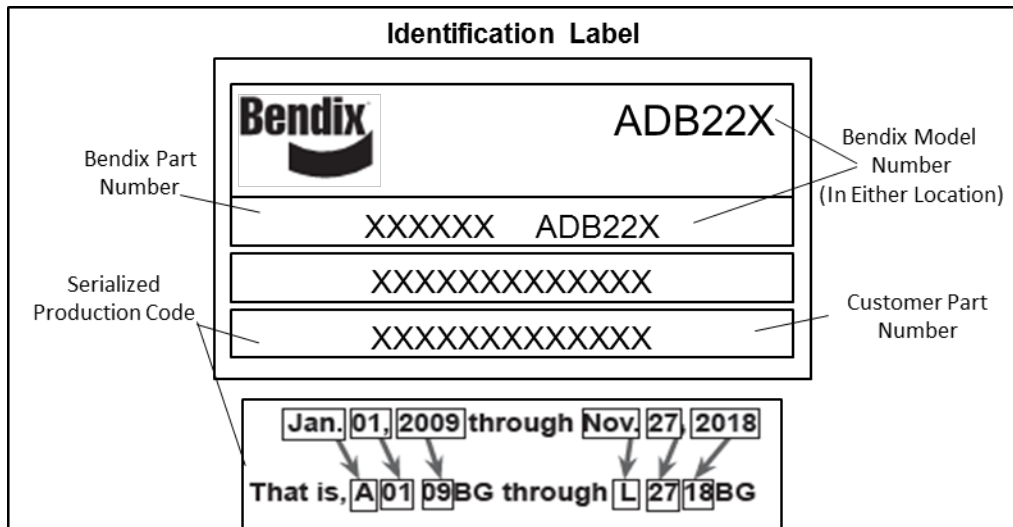

Figure 2: Bendix Label and Date Code Range

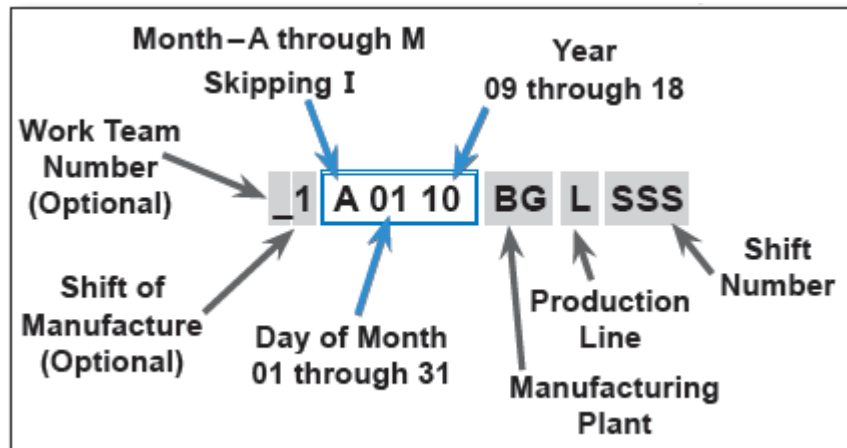

Figure 3: Key to Reading the Date Code

# Recall Campaign

Daimler Trucks  
North America LLC

August 2019  
FL818AB  
NHTSA #19V-444  
Transport Canada #2019-288

## Bendix Warnings

**GENERAL SAFETY GUIDELINES**

**WARNING! PLEASE READ AND FOLLOW THESE INSTRUCTIONS**

**TO AVOID PERSONAL INJURY OR DEATH:**

When working on or around a vehicle, the following guidelines should be observed **AT ALL TIMES**:

- ▲ Park the vehicle on a level surface, apply the parking brakes and always block the wheels. Always wear personal protection equipment.
- ▲ Stop the engine and remove the ignition key when working under or around the vehicle. When working in the engine compartment, the engine should be shut off and the ignition key should be removed. Where circumstances require that the engine be in operation, **EXTREME CAUTION** should be used to prevent personal injury resulting from contact with moving, rotating, leaking, heated or electrically-charged components.
- ▲ Do not attempt to install, remove, disassemble or assemble a component until you have read, and thoroughly understand, the recommended procedures. Use only the proper tools and observe all precautions pertaining to use of those tools.
- ▲ If the work is being performed on the vehicle's air brake system, or any auxiliary pressurized air systems, make certain to drain the air pressure from all reservoirs before beginning ANY work on the vehicle. If the vehicle is equipped with a Bendix® AD-IS® air dryer system, a Bendix® DRM™ dryer reservoir module, or a Bendix® AD-9si® air dryer, be sure to drain the purge reservoir.
- ▲ Following the vehicle manufacturer's recommended procedures, deactivate the electrical system in a manner that safely removes all electrical power from the vehicle.
- ▲ Never exceed manufacturer's recommended pressures.
- ▲ Never connect or disconnect a hose or line containing pressure; it may whip and/or cause hazardous airborne dust and dirt particles. Wear eye protection. Slowly open connections with care, and verify that no pressure is present. Never remove a component or plug unless you are certain all system pressure has been depleted.
- ▲ Use only genuine Bendix® brand replacement parts, components and kits. Replacement hardware, tubing, hose, fittings, wiring, etc. must be of equivalent size, type and strength as original equipment and be designed specifically for such applications and systems.
- ▲ Components with stripped threads or damaged parts should be replaced rather than repaired. Do not attempt repairs requiring machining or welding unless specifically stated and approved by the vehicle and component manufacturer.
- ▲ Prior to returning the vehicle to service, make certain all components and systems are restored to their proper operating condition.
- ▲ For vehicles with Automatic Traction Control (ATC), the ATC function must be disabled (ATC indicator lamp should be ON) prior to performing any vehicle maintenance where one or more wheels on a drive axle are lifted off the ground and moving.
- ▲ The power **MUST** be temporarily disconnected from the radar sensor whenever any tests **USING A DYNAMOMETER** are conducted on a vehicle equipped with a Bendix® Wingman® system.
- ▲ You should consult the vehicle manufacturer's operating and service manuals, and any related literature, in conjunction with the Guidelines above.

**WARNING:** Not all wheels and valve stems are compatible with Bendix® Air Disc Brakes. Use only wheels and valve stems approved by the vehicle manufacturer to avoid the risk of valve stem shear and other compatibility issues.

**WARNING: AVOID CREATING DUST. POSSIBLE CANCER AND LUNG DISEASE HAZARD.**

While Bendix Spicer Foundation Brake LLC does not offer asbestos brake linings, the long-term effects of some non-asbestos fibers have not been determined. Current Occupational Safety and Health Administration (OSHA) Regulations cover exposure levels to some components of non-asbestos linings, but not all. The following precautions must be used when handling these materials.

Avoid creating dust. Compressed air or dry brushing must never be used for cleaning brake assemblies or the work area.

- ▲ Bendix recommends that workers doing brake work must take steps to minimize exposure to airborne brake lining particles. Proper procedures to reduce exposure include working in a well-ventilated area, segregation of areas where brake work is done, use of local filtered ventilation systems or use of enclosed cells with filtered vacuums. Respirators approved by the Mine Safety and Health Administration (MSHA) or National Institute for Occupational Safety and Health (NIOSH) should be worn at all times during brake servicing.
- ▲ Workers must wash before eating, drinking or smoking; shower after working, and should not wear work clothes home. Work clothes should be vacuumed and laundered separately without shaking.
- ▲ OSHA & EPA Regulations regarding testing, disposal of waste, and methods of reducing exposure for asbestos are set forth in 29 & 40 Code of Federal Regulations §1910.1001 & 61.150, respectively. These Regulations provide valuable information which can be utilized to reduce exposure to airborne particles.
- ▲ Safety Data Sheets on this product, as required by OSHA, are available from Bendix. Call 1-800-247-2725 and speak to the Tech Team or e-mail [techteam@bendix.com](mailto:techteam@bendix.com).



# Recall Campaign

Daimler Trucks  
North America LLC

August 2019  
FL818AB  
NHTSA #19V-444  
Transport Canada #2019-288

## Caliper Replacement



When working on the vehicle, shut down the engine, set the parking brake, and chock the tires. Before working under the vehicle, always place jack stands under the frame rails to ensure the vehicle cannot drop. Failure to follow these steps could result in serious personal injury or death.



When using a hoist to support the air disc brake, do not attempt to use the pad retainer bar as a bracing point. It is NOT designed to support the weight of the brake. Instead, use a brace (or chain) wrapped around the entire brake to attach to the hoist.

### SPRING OR SERVICE BRAKE CAGING AND REMOVAL

NOTE: Use the spring brake manufacturer's recommended safety practices in all cases. Some spring brake and vehicle manufacturers permit caging the spring brake while the spring brake is engaged.

1. Raise vehicle and support on jack stands
2. Remove the left rear assembly, then continue to brake pad removal.
3. Apply air to release the spring brakes (parking brakes) by using the dash-mounted air control valve. Back out the release bolt (See **Figure 4, Arrow A**) using a maximum torque of 26 lbf-ft (35 Nm) to cage the air released spring force on the pushrod.
4. Exhaust the air from the spring brake chambers by using the dash-mounted air control valve. While supporting the chamber in position, remove and discard the brake chamber mounting nuts (**Figure 4, Item 4**). Mark the orientation of the chamber to the mounting bracket for remounting. Remove the spring brake chamber. If it becomes necessary to disconnect the air hoses to the chamber, with all the air-pressure drained from the system, mark the hoses for reconnection and then disconnect the hoses from the chamber.

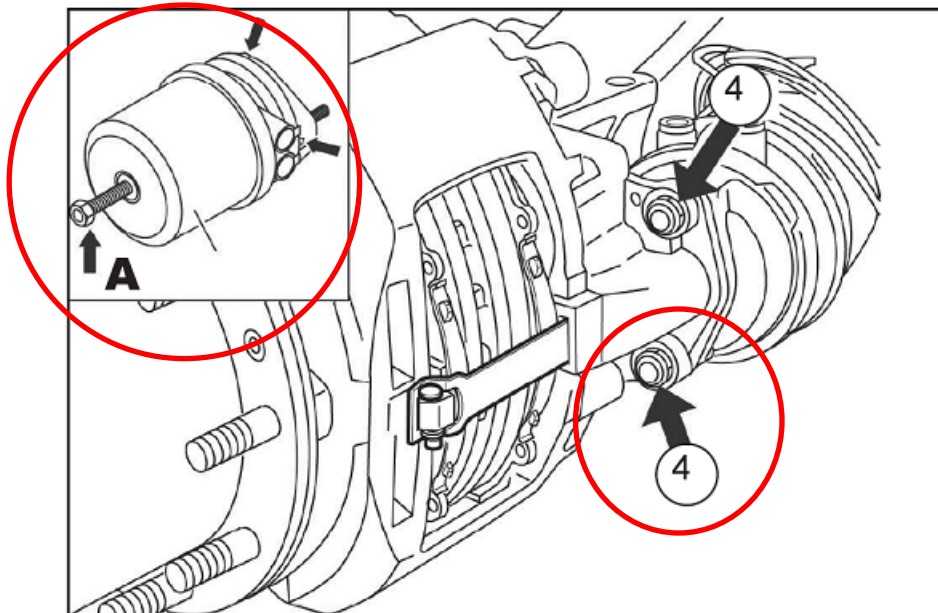

Figure 4: Location of Release Bolt and Mounting Nuts

# Recall Campaign

August 2019  
FL818AB  
NHTSA #19V-444  
Transport Canada #2019-288

## BRAKE PAD REMOVAL

5. Remove and retain the cable protection plate and its mounting hardware. Note the position of the sensors in the brake pad channels, and carefully remove them. In most cases it is not necessary to release the cable connector in order to move the sensors away from the pad installation work area. Inspect the wear sensors, replace if damaged or abraded.
6. While pressing down against the brake pad retaining bar, remove the spring clip, washer, retainer pin, and brake pad retainer bar. See **Figure 5**.
7. Remove and retain the pad shield (if equipped). See **Figure 6**.
8. Follow the steps in the Adjuster Mechanism below. Slide the caliper inboard then outboard to permit easy removal of the brake pads. Remove and retain the brake pads.

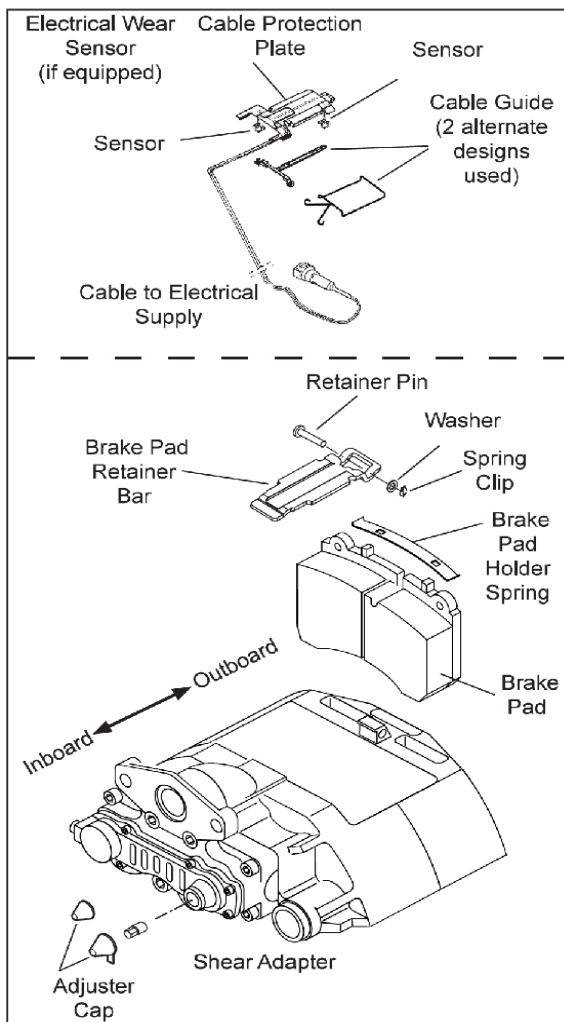

Figure 5: Brake Pad Replacement

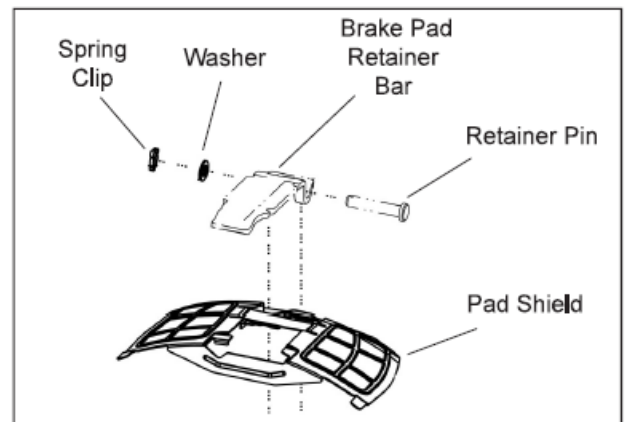

Figure 6: Pad Shield

# Recall Campaign

Daimler Trucks  
North America LLC

August 2019  
FL818AB  
NHTSA #19V-444  
Transport Canada #2019-288

## ADJUSTER MECHANISM

NOTE: One of the two styles of adjuster cap (stamped metal or plastic adjuster cap) may be used. See **Figure 7**.

9. With the spring brake released (or caged), remove the adjuster cap using the tab, taking care not to move the shear adapter.

NOTE: For a more detailed view, see the exploded view in **Figure 8**, showing the adjuster and shear adapter separated. When using the adjuster mechanism, always have the shear adaptor installed on the adjuster.

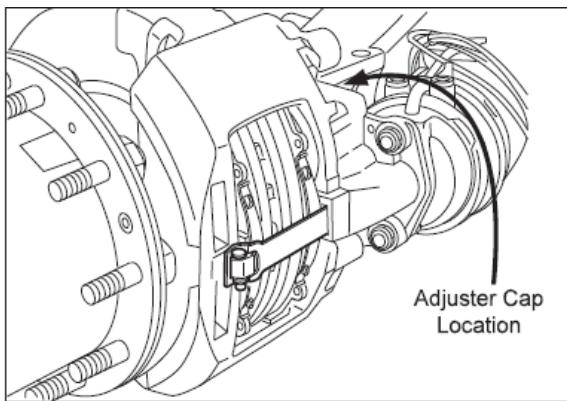

Figure 7: Adjuster Cap Location

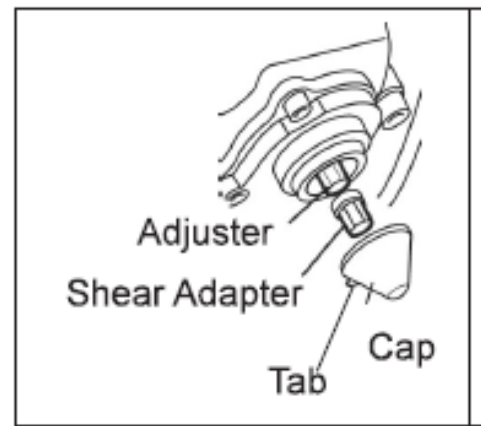

Figure 8: Exploded View of Adjuster and Adaptor

10. Using a 10 mm six-point box wrench, turn the shear adapter counterclockwise and listen for the sound of three (3) clicks as the mechanism backs-off (increases) the running clearance.

---

### CAUTION

---

Never turn the adjuster without the shear adapter installed. The shear adapter is a safety feature and is designed to prevent excessive torque from being applied to the adjuster. The shear adapter will fail (by breaking) if too much torque is applied. Park the vehicle (By other means than the air brake) on level ground and chock wheels.

# Recall Campaign

August 2019  
FL818AB  
NHTSA #19V-444  
Transport Canada #2019-288

## DISASSEMBLY – VERTICAL MOUNTING BOLT STYLE (FL818B)

11. Supporting the air disc brake in a safe way, remove/discard the six mounting bolts. Lift the caliper up off the anchor plate. See **Figure 9, Item 2**.

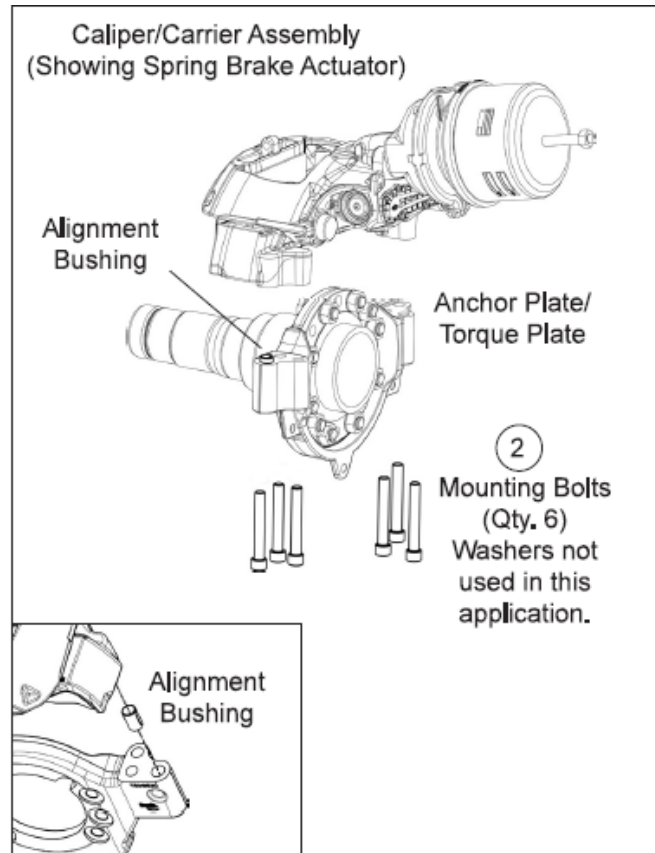

**Figure 9: Vertical Mount Caliper/Carrier**

12. The vertical bolt assembly includes an alignment bushing. This bushing must be saved for reuse during reassembly of the brake. The bushing mounts in the torque plate and maintains the correct alignment of the brake assembly relative to the rotor.
13. If the brake assembly does not separate from the anchor plate it may be helpful to install an M16X2.0 screw longer than the 120 mm at the bushing locations and tap the end of the bolt with a hammer to free the brake assembly. Remove the caliper/carrier assembly

# Recall Campaign

August 2019  
FL818AB  
NHTSA #19V-444  
Transport Canada #2019-288

## DISASSEMBLY – AXIAL MOUNTING BOLT STYLE (FL818A)

14. Supporting the air disc brake in a safe way, remove and discard the six bolts (**Figure 10, Item 2**) and washers (**Figure 10, Item 3**) attaching the brake to the anchor plate and remove the caliper/carrier assembly from the vehicle.

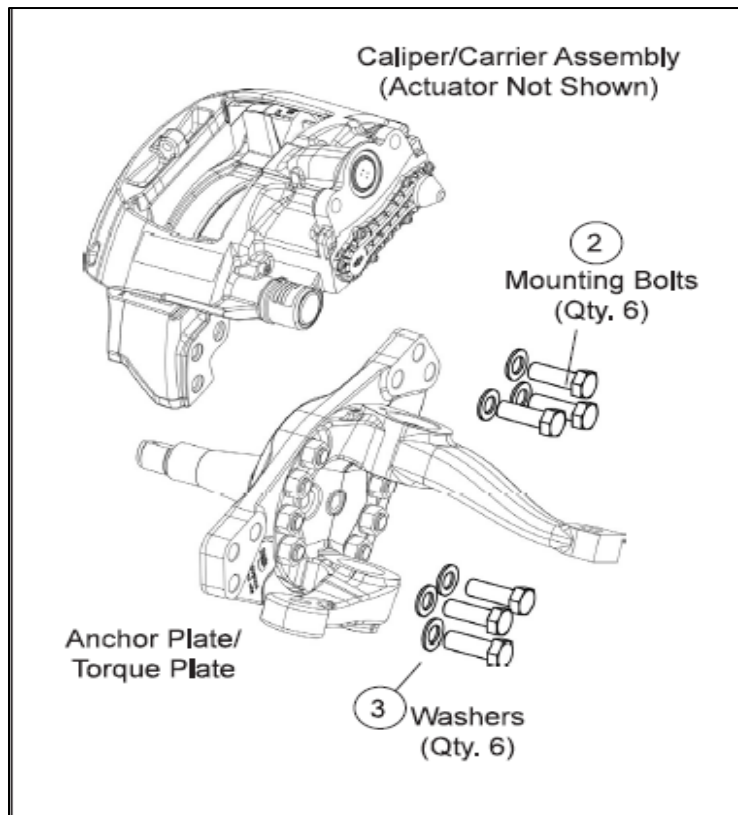

Figure 10: Axial Mount Caliper/Carrier

## CALIPER/CARRIER INSTALLATION (VERTICAL AND AXIAL STYLES)

NOTE: For axial mounted calipers in FL818A, it may be necessary to use DTNA extension tool DSNCHA018005, referenced in tool letter 18TL18 and **Figure 11**. Torque to the values shown in **Figure 12**.

15. Supporting the air disc brake in a safe way, attach the brake to the anchor plate using six bolts (**Figure 10, Item 2**) and, if included, washers (**Figure 10, Item 3**). Do not reuse removed bolts and washers.



Figure 11: DTNA Extension Tool

# Recall Campaign

Daimler Trucks  
North America LLC

August 2019  
FL818AB  
NHTSA #19V-444  
Transport Canada #2019-288



Air Disc Brake Attachment Hardware	
<b>Vertical Mount</b>  Service Actuators Shown   <p>Left-hand Brake      Right-hand Brake</p> <p>Short (floating) Pin</p> <p>Sheer Sleeve      Shelf      Sheer Sleeve</p> <p>Washers are not used on vertical-mounted ADB22X™ brake assemblies</p>	<b>Fastener &amp; Torque*</b>  <b>Thomas Built®</b> <b>Mounting Bolts (Item 2):</b> M16 x 2.0 x 110 mm, Class 12.9. <i>Use the new fasteners included.</i>  <b>Washer (Item 3):</b> None used.  <b>Torque:</b> Using the torque pattern below, pre-torque to between 40-50 ft-lbf [54-68 N-m], with a final torque of 229 ft-lbf [310 N-m].
<b>Left-Hand Brake Torque* Pattern (Viewed from Below)</b>  Brake's short (floating Pin) is this side   <p>(view from below)</p> <p>Sheer sleeve above, in this location      Shelf above, in this location</p>	<b>Right-Hand Brake Torque* Pattern (Viewed from Below)</b>  Brake's short (floating pin) is this side   <p>(view from below)</p> <p>Shelf above, in this location      Sheer sleeve above, in this location</p>
<b>Axial Mount</b>  Caliper/Carrier Assembly (showing service actuator)   <p>Anchor Plate/Torque Plate</p>	<b>Thomas Built</b> <b>Mounting Bolts (Item 2):</b> M20 x 60 mm Class 10.9. <b>Torque:</b> Pre-torque to 20-60 ft-lbf [27-81 N-m], with a final torque of 375 ft-lbf [510 N-m]. <b>Washer (Item 3):</b> Use the new mounting bolts and washers included.
<b>Torque* Pattern</b>  Any cross-pattern, see the example below:  	
<small>*Use the new fasteners included in the kit when installing the air disc brake caliper. Ensure that the brake caliper guide pins slide freely once the final torque has been achieved on all fasteners. Refer to the OE maintenance manuals for vehicle specific installation recommendations.</small>	

Figure 12: Torque Plate Fasteners and Torque Recommendations

# Recall Campaign

Daimler Trucks  
North America LLC

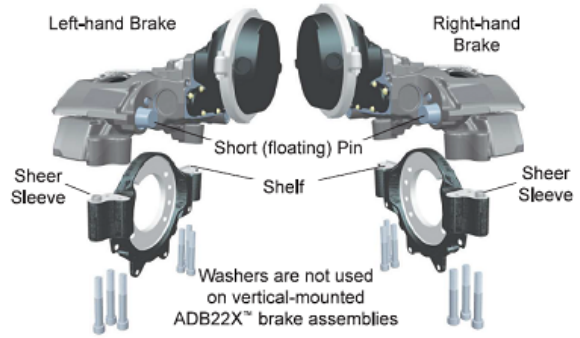
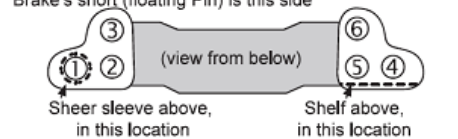
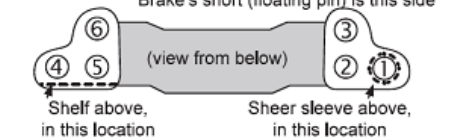
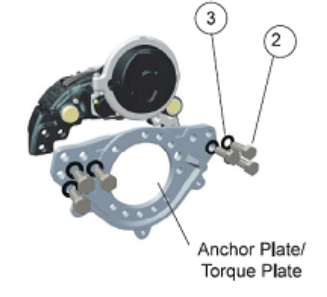
August 2019  
FL818AB  
NHTSA #19V-444  
Transport Canada #2019-288

## SPRING OR SERVICE BRAKE REINSTALLATION

### CAUTION

Do not use spring brake chambers with seals that have a thickness less than .12 in. (3 mm). Use only actuators which are recommended by the vehicle manufacturer.

16. Ensure the spring brake chamber mounting is clean and free of any debris. See **Figure 13, Item B**.

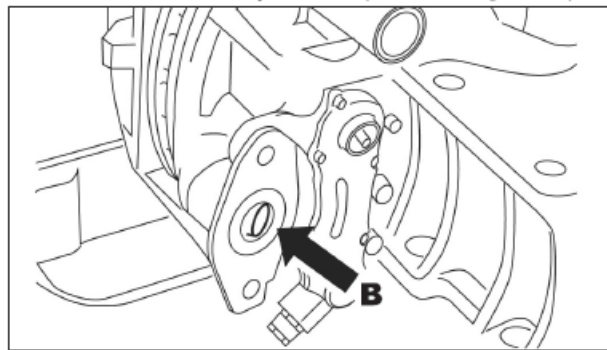

Figure 13: Spring Brake Installation

17. Position the spring brake chamber in the same orientation it was removed. Secure the chamber with the spring brake chamber mounting nuts (**Figure 4, Item 4**). Alternately, tighten both the nuts step-by-step to a final torque of 133 +/- 7 lbf·ft (180 +/- 10 Nm). Do not reuse nuts removed during the disassembly.

NOTE: Spring brake service chamber ports are indicated by: “11” service brake port and “12” spring brake port. See **Figure 14**.

NOTE: If a new spring brake chamber is being installed, note that the chamber may contain drain plugs installed around the perimeter of the body. If drain plugs are present, after installation, remove whichever plug is at the lowest position. The selected drain hole must be aligned downwards (or within +/- 30 degrees) when installed in the vehicle.

18. If the air hoses were disconnected, reconnect the air hoses as marked, ensuring that each hose is not twisted or in contact with moving vehicle components. The air hose routing must allow for full caliper travel.

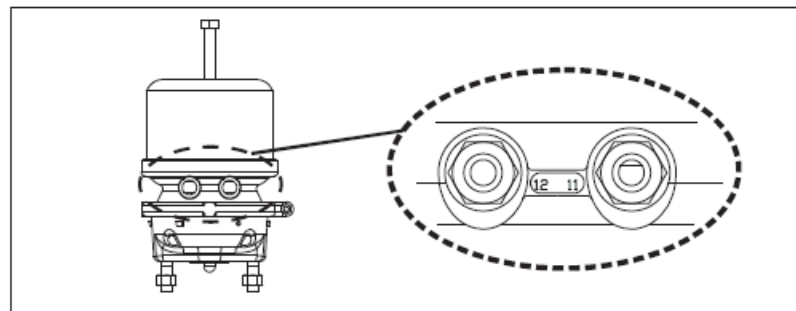

Figure 14: Port Designations

# Recall Campaign

Daimler Trucks  
North America LLC

August 2019  
FL818AB  
NHTSA #19V-444  
Transport Canada #2019-288

## BRAKE PAD REPLACEMENT

### WARNING

When replacing brake pads, shoes, rotors, or drums, always replace components as an axle set.

- Always reline both sets of brakes on an axle at the same time.
- Always replace both rotors/drums on an axle at the same time.
- Always install the same type of linings/pads or drums/rotors on both axle ends of a single axle, and all four axle ends of a tandem axle, at the same time. Do not mix component types.

Failure to do so could cause uneven braking and loss of vehicle control, resulting in property damage, personal injury, or death.

### CAUTION

When installing pads and retaining springs, where appropriate, use heavy duty gloves and always keep fingers away from potential pinch hazard areas.

19. Clean the surfaces that will come in contact with the brake pad.
20. Install the brake pad retaining springs onto the brake pads by inserting one end of the spring onto the lug at the top of the brake pad. Carefully apply enough force to permit the second lug to fully engage, taking care to keep fingers, etc. away from the spring as it seats. **See Figure 15.**

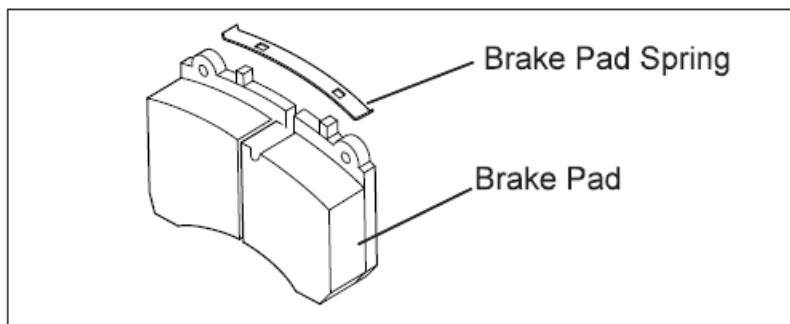

**Figure 15: Pad Retaining Spring Installation**

21. Pull the caliper fully outward and install the outboard pad. Move the caliper fully inward and install the inboard pad.
22. To reinstall wear indicators (if used) insert the wear sensors into position in the new brake pads. Route the sensor cable through the cable protection plate channel and secure the plate with the mounting hardware removed when removing the brake pads.
23. Push the pad retainer bar into the groove of the caliper. Press down on the pad retainer bar and insert the pad retainer pin, with the pin pointing downward, where possible. Install the washer and then the spring clip. See **Figure 5.**

NOTE: Do not use an open-ended wrench, as this may damage the adaptor.

24. Using a 10mm, six point box wrench, turn the shear adapter clockwise until the pads contact the rotor. See **Figure 16.**



# Recall Campaign

Daimler Trucks  
North America LLC

August 2019  
FL818AB  
NHTSA #19V-444  
Transport Canada #2019-288

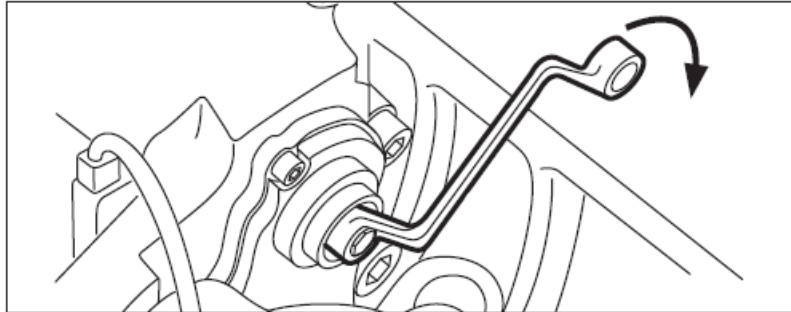

**Figure 16: Clockwise Rotation**

NOTE: If the shear adapter fails, you may attempt a second time with a new (unused) shear adaptor. Always double-check that the spring brake is released (where applicable) if a shear adapter fails. If this step was missed, the shear adaptor will break off, and it may appear that the caliper seized. In cases where a second failure of the shear adaptor confirms that the adjustment mechanism is seized, the caliper must be replaced.

25. Using the same tool, turn the sear adapter counterclockwise and listen for the sound of 3 clicks as the mechanism backs-off (increases) the running clearance. See **Figure 17**.

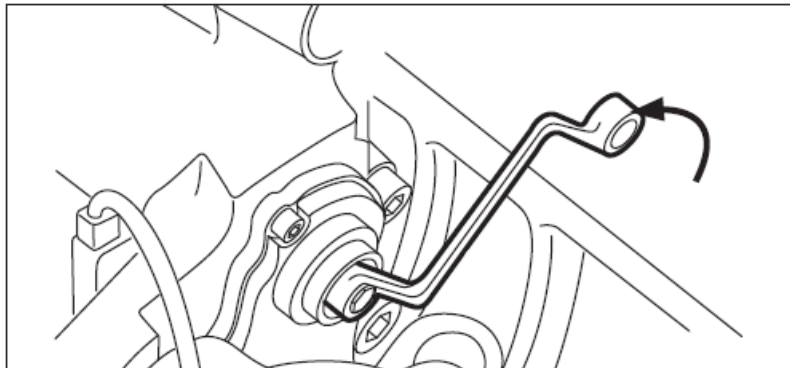

**Figure 17: Counterclockwise Rotation**

26. Replace the adjuster cap.
27. Start engine to build air pressure. Once full system air is achieved, shut off engine.
28. Push in on the park brake valve on the dash to release the park brakes.
29. Un-cage the park brake spring actuator. Replace the cage bolt for future service use if removed from actuator.
30. Check for air leaks.
31. Apply and release the brakes. The hub should turn easily by hand after applying and releasing the brake.
32. Recheck the running clearance. Readjust if necessary.
33. Reinstall the wheel assembly.
34. Raise vehicle, remove jack stands, then lower vehicle.
35. Remove the chocks from the tires.

# Recall Campaign

Daimler Trucks  
North America LLC

August 2019  
FL818AB  
NHTSA #19V-444  
Transport Canada #2019-288



## WARNING

**Do not operate the vehicle until the brakes have been adjusted and checked for proper operation. To do so could result in inadequate or no braking ability, which could cause personal injury or death, and property damage.**

36. In a safe area, check for proper brake operations, as follows, before putting the vehicle in service.
  - 33.1 Apply and release the brakes several times to check for air leaks and proper operations.
  - 33.2 Perform six low-speed stops to ensure proper parts replacement and full vehicle control.
  - 33.3 Immediately after doing the above stops, check the rotor temperatures. Any rotors that are significantly cooler than others indicate a lack of braking effort on those wheels.
37. Prepare removed calipers for return (shipment to Bendix is at no charge to the dealership).
  - 37.1 Package one to two (1 to 2) calipers in the packaging from the Bendix recall kits. Palletize three (3) or more calipers.
  - 37.2 Include a copy of the recall claim for each caliper in a shipment.
  - 37.3 Ship one to two (1 to 2) calipers to Bendix via UPS using account number 2AT516. See "ship to" address below.
  - 37.4 Ship pallets of three (3) or more calipers to Bendix with the completed shipment information form downloaded from: [http://www.bendix.com/en/service/support/recallcenter/recallcenter\\_1.jsp](http://www.bendix.com/en/service/support/recallcenter/recallcenter_1.jsp). Call Central Transport at (586) 467-1900 to coordinate pick up. See "ship to" address below.

**Ship to Address for all Shipments:**

Bendix Warranty Center  
1155 E Franklin St.  
Huntington, IN. 46750  
ATTN: Recall Returns
38. For FCCC chassis in FL818B, clean a spot on the base label (Form WAR259). Write the recall number, FL818, on a completion sticker (Form WAR260), and attach it to the base label to indicate this recall has been completed. For TBB buses in FL818A, the procedure is complete.